

Competencies and Services for the Development and Optimization  
of Rotor Bearing Systems with Main Focus on Aerodynamic Gas Bearings

# SADAP

ADAPTIVE SOLUTIONS

**KNOWLEDGE SHINES**

SADAP UG (haftungsbeschränkt)  
Tel: +49/ (0)531 12287547  
Fax: +49/ (0)531 3917053  
Email: [info@sadap.de](mailto:info@sadap.de)  
Website: [www.sadap.de](http://www.sadap.de)

## AERODYNAMIC FOIL-BEARING TECHNOLOGY



### Air as Lubricant

without external pressure supply.

### Compliant Foil

- More flexibility against deformation of the journal due to mechanical and thermal stresses.
- additional damping mechanism for more stability

### Bearing Journal

Rotating part

### Housing

Stationary part

### Journal Bearing

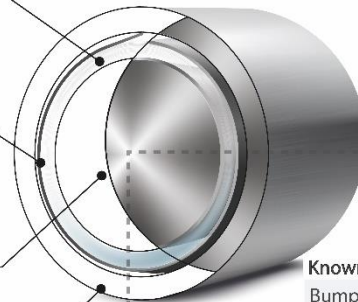

#### Known types of foil structure

##### Bump - Type

Clearance > 0



##### Leaf - Type

Clearance < 0  
(Mechanical Preload)



## PRINCIPLE OF LUBRICATION

The hydrodynamic pressure build-up counteracts the weight of the rotating part and enables frictionless operation after lift-off.

## FIELDS OF APPLICATION

Light rotors in: Automotive industry (fuel cells), power engineering, aerospace, medical technology, textile industry, etc.

## BENEFIT

- Non polluting since no oil is used for the lubrication
- Minimum sensitivity to operating temperatures
- No external pressure supply is required
- Stable operation up to high speeds (above 100 krpm)

**KNOWLEDGE SHINES**

## ROTOR-BEARING ANALYSIS



### Our Services and Products Based on Simulations

Modern numerical tools for the bearing calculation in e. g. turbomachinery under consideration of the different static and dynamic properties, with the aim of:

Development and dimensioning:

- Load capacity
- Static and dynamic stiffnesses and dampings
- Journal orbits and motion errors
- Waterfall diagrams to spot the self-excited motions

Diagnoses and optimizations:

- Manufacturing uncertainties
- Optimization with regard to wear problems
- Improvement of load capacity
- Improvement of stability

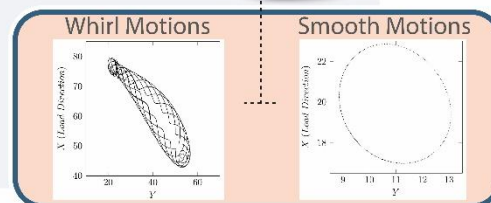
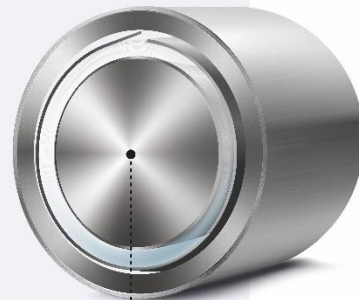

Further steps of analysis considering the rotating shafts supported by bearings to identify the possible resonances and the vibrational amplitude, using:

- Critical speed map
- Stability analysis
- Amplitude of shaft's displacements
- Modal analysis



**KNOWLEDGE SHINES**

## ROTOR-BEARING ANALYSIS

**SADAP**  
ADAPTIVE SOLUTIONS

### Analysis and Development Based on Experiment



SADAP supports customers with various ready-to-use test rigs to validate the numerical models used for the developments, optimizations and analyses taking into account different operating conditions, in order to target the specific characteristics of the rotor bearing system, including:

- Lift-off behavior (using a low speed test rig for operation up to 30 krpm)
- Coefficients of friction with regard to the wear problems
- Journal orbits to extract the whirl frequencies and motion errors
- Stiffness and damping characteristics in operation (both static and dynamic for small and large amplitudes of external excitations)
- Frequency-dependent dynamic coefficients of the foil structure out of operation (for compliant bearings)

Analyses based on numerical and experimental tools for:

- Herringbone bearing (Air)
- Tilting - Pad bearing (Air)
- Bump - Foil bearing (Foil)
- Leaf (Garret) - Type bearing (Foil)
- Aerostatic bearings with external pressurization (Air)

And any exceptional type of compliant and noncompliant gas lubricated bearings

Types of bearing SADAP can offer technical services for, within the framework of customer defined projects:

- Hydrodynamic oil-bearings
- Magnetic bearings
- Ball bearings
- Cylindrical roller bearings



**KNOWLEDGE SHINES**

## ROTOR-BEARING ANALYSIS

**SADAP**  
ADAPTIVE SOLUTIONS

### High-Speed Test Rig

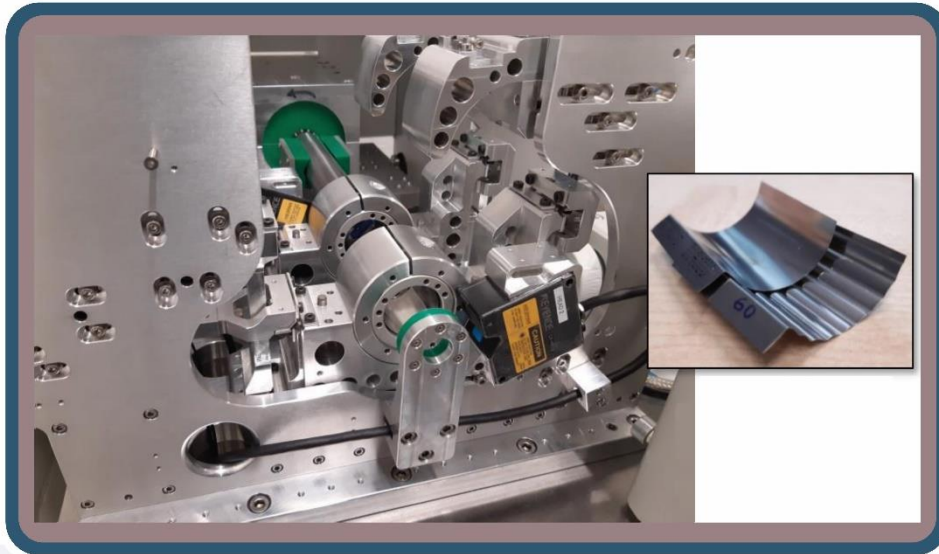

In cooperation with the TU Braunschweig, the test rig is used for the experimental investigation of radial air bearings for the analysis of various static and dynamic properties in the high-speed range. Some specifications of the test rig can be listed as follows:

**Concept:** Conventional design with "floating" shaft

**Number of bearings:** 2 (or 1 + 1 support bearing)

**Test target:** Behavior at high speeds, Run-out behavior,  
Rotor dynamics

**Max. Diameter of test bearings:** 80 mm  
(outer diameter bushing)

**Radial load:** Flow channel ( magnetic effect)

**Speed:** 10 - 120 krpm

**Torque:** Auxiliary motor: 4 Nm,  
Main motor: 0.3 Nm (3.5 kW)

**Force/Torque measurement:** Strain gauge,  
full bridges

**Temperature measurement:** Pt100 (bonded)

**KNOWLEDGE SHINES**



## ROTOR-BEARING ANALYSIS

**SADAP**  
ADAPTIVE SOLUTIONS

### Low-Speed Test Rig

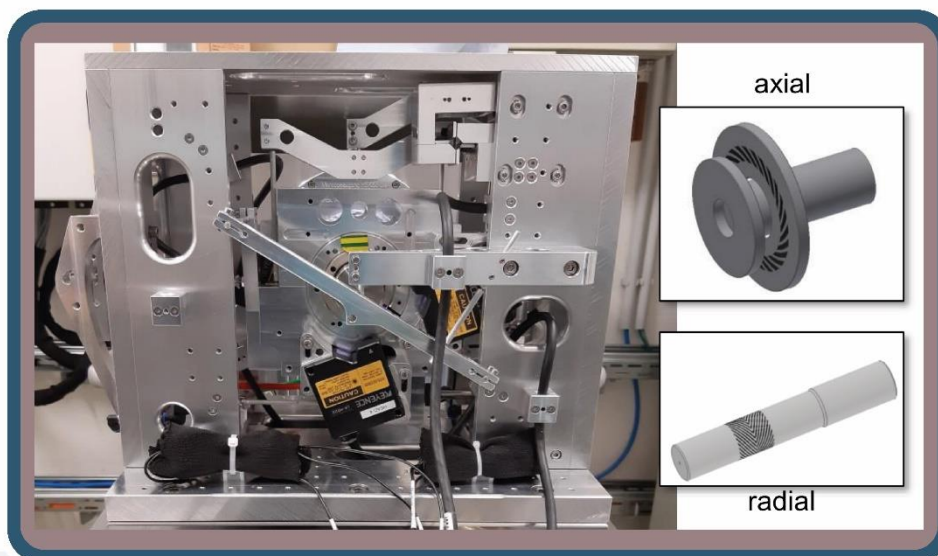

In cooperation with TU Braunschweig, the test rig is used for the experimental investigation of radial air bearings for the analysis of static and dynamic properties in the low speed range. Some specifications of the test rig can be listed as follows:

<b>Concept:</b> Floating" bearing, the rotor is rigidly mounted, the bearing is gimbaled and locked against rotation	<b>Radial load:</b> 0 - 50 N (pneumatic cylinder)
<b>Number of bearings:</b> 1	<b>Axial load:</b> 0 - 300 N (pneumatic cylinder)
<b>Test target:</b> Starting friction, Lift-off behavior	<b>Speed:</b> 0 - 30 krpm (+/- 150 rpm)
<b>Displacement (gap) measurement:</b> Lasertriangulation $\pm 3 \text{ mm} / 0.02 \mu\text{m}$	<b>Torque:</b> Min. 4 Nm (37 kW)
	<b>Force/ Torque measurement:</b> Strain gauge, full bridges
	<b>Temperature measurement:</b> Pt100 (bonded)

**KNOWLEDGE SHINES**

## ROTOR-BEARING ANALYSIS

### Air Conditioned Tribometer

**SADAP**  
ADAPTIVE SOLUTIONS

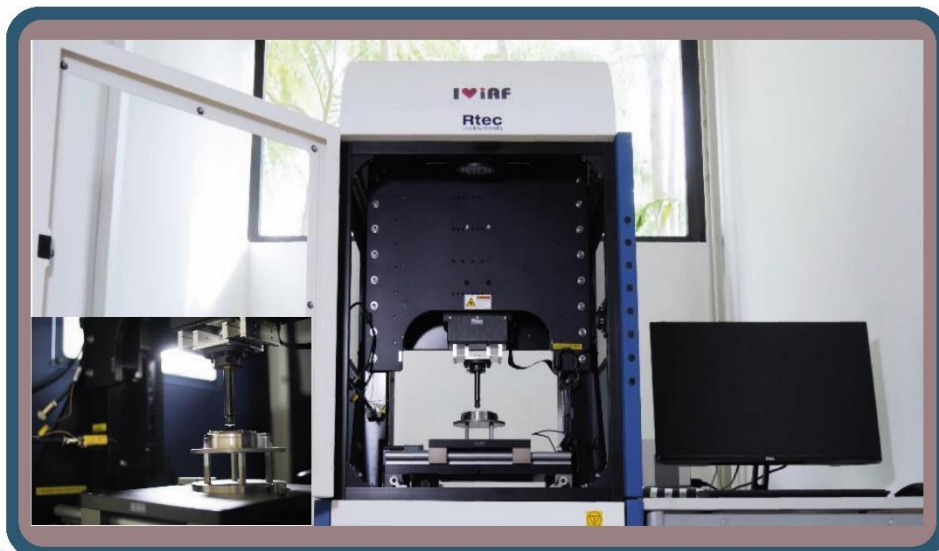

A tribometer is a machine used to perform tests of wear, friction and lubrication that underlies tribology. Conducting tests using tribometers is particularly effective in investigating the friction pairing of coated surfaces in bearings.

Test arrangement:	pin-disk, ball-disk, ring-blocks (rotatory/oscillatory)
Humidity:	3% to 95%
Temperature:	-40 to 400 °C
Normal load:	up to 50 N
Speed:	0.1 - 8000 rpm (pin-disk), 0.1 - 5000 rpm (ring-block)

**KNOWLEDGE SHINES**